

APPROVAL - CUSTOMER NAME & SIGNATURE

DATE

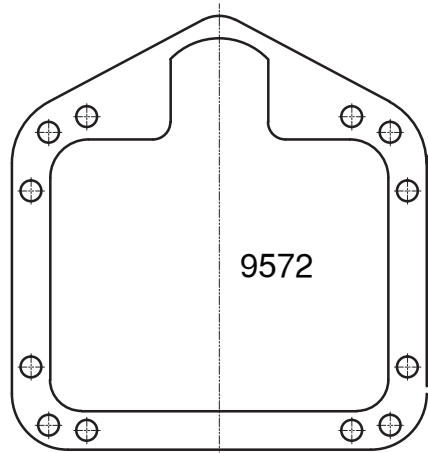
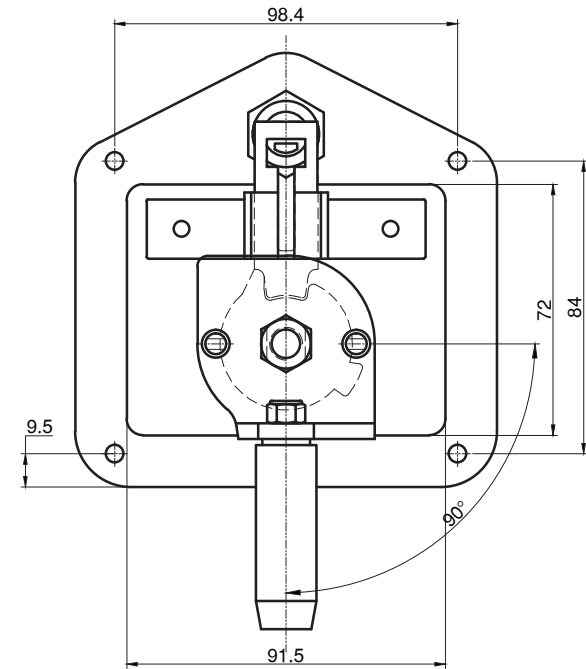
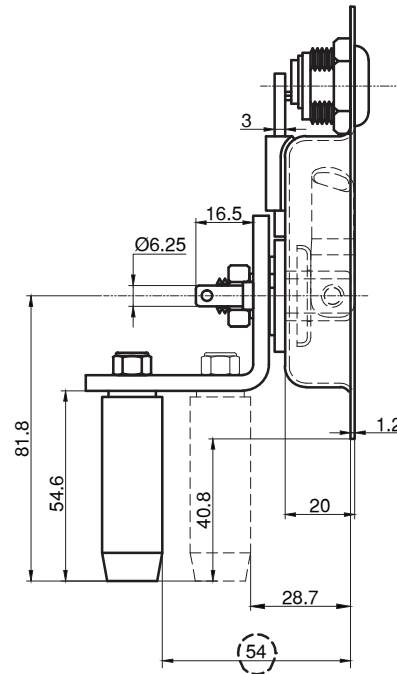
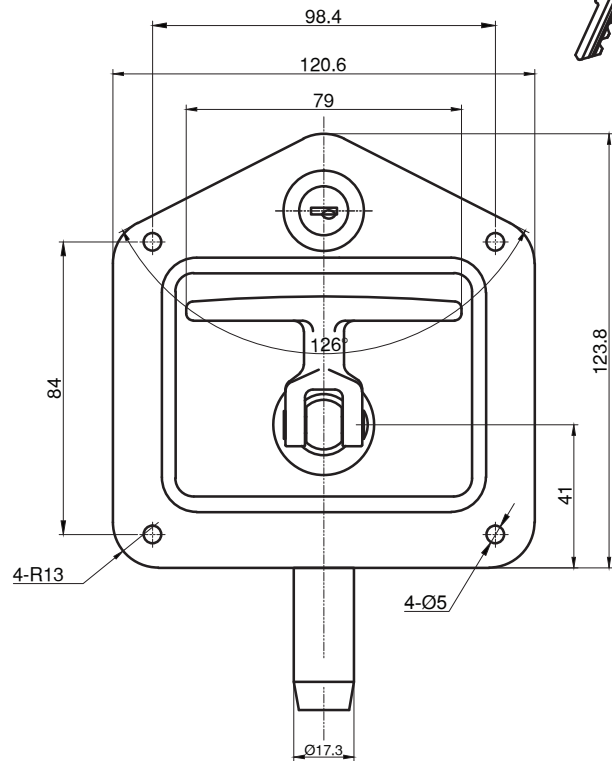

		TOLERANCES FOR UNSPECIFIED DIMENSIONS							
		SIZE	A	B	SIZE	A	B		
MATERIAL: Stainless Steel 304		DRAWING NO.: LA 8600 SS		5 under	±0.15	±0.20	250=>500	±0.60	±1.00
FINISH: Material Finish: Brushed (s/s) Stainless Steel		REV.: 1:2		5=>10	±0.20	±0.30	500=>750	±0.80	±1.20
DATE: 03-03-2010				10=>25	±0.25	±0.40	750=>up	±1.20	±1.50
				25=>50	±0.30	±0.45	*A: CENTER TO CENTER *B: OTHERS DIMENSIONS *ANGLE ±1.0°		Unit mm
				50=>100	±0.40	±0.60			
				100=>250	±0.50	±0.80			